

# MIAMI TECH, INC.

## MECHANICAL UNIT STEEL TIE-DOWN CLIP: AT GRADE & ROOF-TOP MOUNTED APPLICATIONS

NON-SITE-SPECIFIC STRUCTURAL PERFORMANCE EVALUATION. A DESIGN PROFESSIONAL SHALL BE RESPONSIBLE FOR CERTIFYING THE APPLICATION OF THIS INFORMATION TO ANY SITE-SPECIFIC LOCATION.

FRANK BENNARDO, PE  
PE# 0046549 CA# 9885

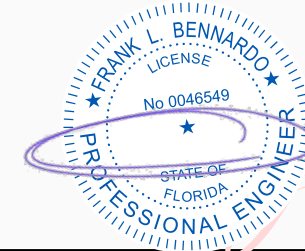

Digitally signed by  
Frank Bennardo  
Date: 2023.08.21  
10:44:34 -04'00'

### STEEL TIE-DOWN CLIP

#### SIDE VIEW TYP.

ALL OTHER CLIPS SIMILAR  
VARYING LENGTH ONLY

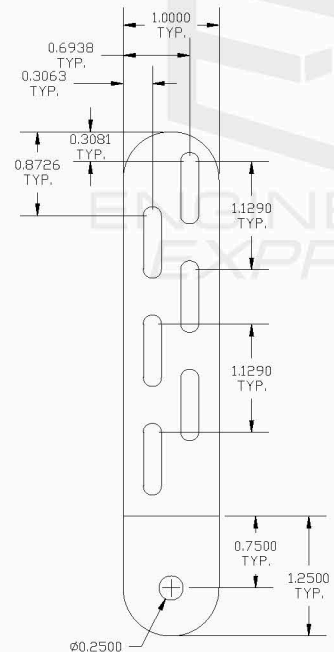

1  
1  
**4" LONG CLIP**  
N.T.S. FLATTENED



3  
1  
**8" LONG CLIP**  
N.T.S. FLATTENED

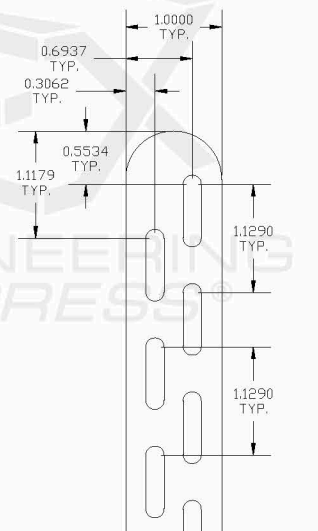

4  
1  
**10" LONG CLIP**  
N.T.S. FLATTENED

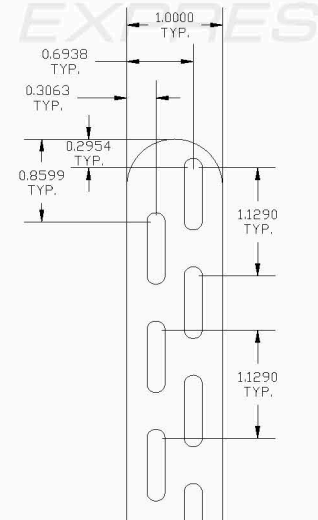

5  
1  
**12" LONG CLIP**  
N.T.S. FLATTENED

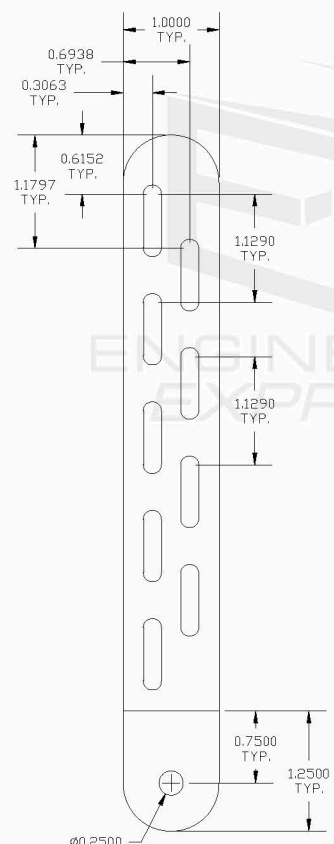

2  
1  
**6" LONG CLIP**  
N.T.S. FLATTENED

#### NOTE REGARDING USE OF THIS DOCUMENT & USE OUTSIDE FLORIDA:

NON-SITE-SPECIFIC STRUCTURAL PERFORMANCE EVALUATION. THIS PRODUCT EVALUATION IS VALID FOR USE IN **FLORIDA ONLY**. USE OF THIS EVALUATION REQUIRES A REVIEW & CERTIFICATION BY A LOCAL DESIGN PROFESSIONAL WHO SHALL BE RESPONSIBLE FOR THE PROPER ADAPTATION OF THIS GENERAL PERFORMANCE EVALUATION TO ANY SITE-SPECIFIC PROJECT. CONTACT THIS OFFICE AT **ENGINEERINGEXPRESS.COM/QUOTE** FOR ASSISTANCE WITH YOUR PROJECT-SPECIFIC NEEDS & FOR ADAPTATION & CERTIFICATION OF THIS DOCUMENT OUTSIDE OF FLORIDA.

#### DESIGN NOTES:

- THIS PRODUCT HAS BEEN DESIGNED IN ACCORDANCE WITH ASCE 7-22 AND THE FLORIDA BUILDING CODE 8th EDITION (2023) FOR USE WITHIN AND OUTSIDE THE HIGH VELOCITY HURRICANE ZONE AS INDICATED IN THE ACCOMPANYING DESIGN SCHEDULES. THE DESIGN CRITERIA USED TO CALCULATE THE ALLOWABLE ROOF-TOP HEIGHTS CONSIDERS FBC CHAPTER 16:  $(G_C)_{Lateral} = 1.90$  WITHIN THE HVHZ & OUTSIDE THE HVHZ,  $(G_C)_{Uplift} = 1.5$  FOR ALL LOCATIONS (CONCURRENT).
- ALL OTHER DESIGN VARIABLES ARE IN ACCORDANCE WITH ASCE 7 CHAPTERS 26 & 29.
- THE HEIGHTS LISTED IN THE DESIGN SCHEDULES REPRESENT THE ALLOWABLE HEIGHT OF THE BUILDING.
- THIS PRODUCT APPROVAL ALLOWS FOR EACH UNIT TO BE INSTALLED ON A MAXIMUM 30" TALL A/C STAND (CERTIFICATION BY OTHERS) ON TOP OF THE HEIGHTS LISTED IN THE DESIGN SCHEDULES.
- NO 33-1/3% INCREASE IN ALLOWABLE STRESS HAS BEEN USED IN THE DESIGN OF THIS SYSTEM.
- DESIGN IS BASED ON CLIENT PROVIDED PRODUCT AND DIE SHEETS FROM TEST REPORT PROJECT #15-6206 BY FENESTRATION TESTING LABORATORY, INC.. NO SUBSTITUTIONS WITHOUT WRITTEN APPROVAL BY THIS ENGINEER SHALL BE PERMITTED.
- STEEL CLIPS SHALL BE ASTM A653 STEEL WITH  $F_y = 33$  KSI OR BETTER. STEEL MEMBERS SHALL BE PROTECTED AGAINST CORROSION WITH AN APPROVED COAT OF PAINT, ENAMEL OR OTHER APPROVED PROTECTION. G90-RATED COATING REQUIRED FOR COASTAL INSTALLATIONS.

#### GENERAL NOTES:

- THIS PRODUCT HAS BEEN DESIGNED AND SHALL BE FABRICATED IN ACCORDANCE WITH THE REQUIREMENTS OF THE FLORIDA BUILDING CODE & ASCE 7. THIS PRODUCT MAY BE USED WITHIN AND OUTSIDE THE HIGH VELOCITY HURRICANE ZONE.
- MAXIMUM & MINIMUM DIMENSIONS AND MINIMUM WEIGHT OF MECHANICAL UNIT SHALL CONFORM TO SPECIFICATIONS STATED HEREIN. ALL MECHANICAL SPECIFICATIONS (CLEAR SPACE, TONNAGE, ETC.) SHALL BE AS PER MANUFACTURER RECOMMENDATIONS AND ARE THE EXPRESS RESPONSIBILITY OF THE CONTRACTOR.
- FASTENERS TO BE #10 X 3/4" OR GREATER STAINLESS STEEL 410 UNLESS NOTED OTHERWISE. ANCHORS REFERRED TO HEREIN SHALL BE ELCO BRAND, STAINLESS STEEL ONLY, INSTALLED TO 3000 PSI MIN CONCRETE. SEE ANCHOR TO HOST SCHEDULE FOR ANCHOR REQUIREMENTS. ALL FASTENERS SHALL HAVE APPROPRIATE CORROSION PROTECTION TO PREVENT ELECTROLYSIS.
- ALL CONCRETE SPECIFIED HEREIN IS NOT PART OF THIS CERTIFICATION. AS A MINIMUM, ALL CONCRETE SHALL BE STRUCTURAL CONCRETE 4" MIN. THICK AND SHALL HAVE MINIMUM COMPRESSIVE STRENGTH OF 3000 PSI, UNLESS NOTED OTHERWISE.
- THE CONTRACTOR IS RESPONSIBLE TO INSULATE ALL MEMBERS FROM DISSIMILAR MATERIALS TO PREVENT ELECTROLYSIS.
- ELECTRICAL GROUND, WHEN REQUIRED, TO BE DESIGNED & INSTALLED BY OTHERS.
- THE ADEQUACY OF ANY EXISTING STRUCTURE TO WITHSTAND SUPERIMPOSED LOADS SHALL BE VERIFIED BY THE ONSITE DESIGN PROFESSIONAL AND IS NOT INCLUDED IN THIS CERTIFICATION. EXCEPT AS EXPRESSLY PROVIDED HEREIN, NO ADDITIONAL CERTIFICATIONS OR AFFIRMATIONS ARE INTENDED.
- THE SYSTEM DETAILED HEREIN IS GENERIC & DOES NOT PROVIDE INFORMATION FOR A SPECIFIC SITE. THESE PLANS SHALL BE USED ALONG WITH SITE SPECIFIC PLANS & INFORMATION BY OTHERS TO CONSTITUTE APPROVAL FOR PERMIT & CONSTRUCTION.
- WATER-TIGHTNESS OF EXISTING HOST SUBSTRATE SHALL BE THE FULL RESPONSIBILITY OF THE INSTALLING CONTRACTOR. CONTRACTOR SHALL ENSURE THAT ANY REMOVED OR ALTERED WATERPROOFING MEMBRANE IS RESTORED AFTER FABRICATION AND INSTALLATION OF STRUCTURE PROPOSED HEREIN. THIS ENGINEER SHALL NOT BE RESPONSIBLE FOR ANY WATERPROOFING OR LEAKAGE ISSUES WHICH MAY OCCUR AS WATER-TIGHTNESS SHALL BE THE FULL RESPONSIBILITY OF THE INSTALLING CONTRACTOR.
- FOR AN EXPLANATION OF EXPOSURE AND RISK CATEGORIES THAT ACCOMPANY THE VULNERABILITY WIND SPEEDS USED IN THIS APPROVAL, SEE ASCE 7.

VISIT [ECALC.IO/61594](http://ECALC.IO/61594)

FOR SITE SPECIFIC DEVIATIONS  
& MORE INFORMATION ABOUT THIS DOCUMENT  
OR SCAN THIS QR CODE

VISIT [ENGINEERINGEXPRESS.COM/MIAMITECH](http://ENGINEERINGEXPRESS.COM/MIAMITECH)  
FOR ADDITIONAL PLANS, REPORTS & RESOURCES



FL19731.2

**ENGINEERING EXPRESS**  
POSTAL ADDRESS:  
401 W. ATLANTIC AVE R10 BOX 219  
DELRAY BEACH, FL 33444  
ENGINEERINGEXPRESS.COM

**MIAMI TECH, INC**  
361 NW, 74TH ST  
MIAMI, FL 33147  
(305) 693 - 7054  
MIAMI TECH TIE DOWN CLIP  
FL STATEWIDE APPROVAL  
FLORIDA BUILDING CODE

REMARKS	DRWN	CHKD	DATE
INIT ISSUE	LAO	TSB	2/05/16
2017 FBC	LAO	FLB	8/14/17
2020 FBC	CCB	RWN	6/09/20
2021 FORMATTING	CCH	RWN	11/19/21
2023 FBC	RN	RN	8-15-23

23-61594

SCALE: NTS UNLESS NOTED

1 OF 6



FL19731.2

**ENGINEERING EXPRESS®**  
 POSTAL ADDRESS:  
 401 W. ATLANTIC AVE R10 BOX 219  
 DELRAY BEACH, FL 33444  
 ENGINEERINGEXPRESS.COM

**MIAMI TECH, INC**  
 361 NW, 74TH ST  
 MIAMI, FL 33147  
 (305) 693 - 7054  
 MIAMI TECH TIE DOWN CLIP  
 FL STATEWIDE APPROVAL  
 FLORIDA BUILDING CODE

REMARKS	DRWN	CHKD	DATE
INIT ISSUE	LAO	TSB	2/05/16
2017 FBC	LAO	FLB	8/14/17
2020 FBC	CCB	RWN	6/09/20
2021 FORMATTING	CCH	RWN	11/19/21
2023 FBC	RN	RN	8-15-23

23-61594

SCALE: NTS UNLESS NOTED

STEEL TIE-DOWN CLIP

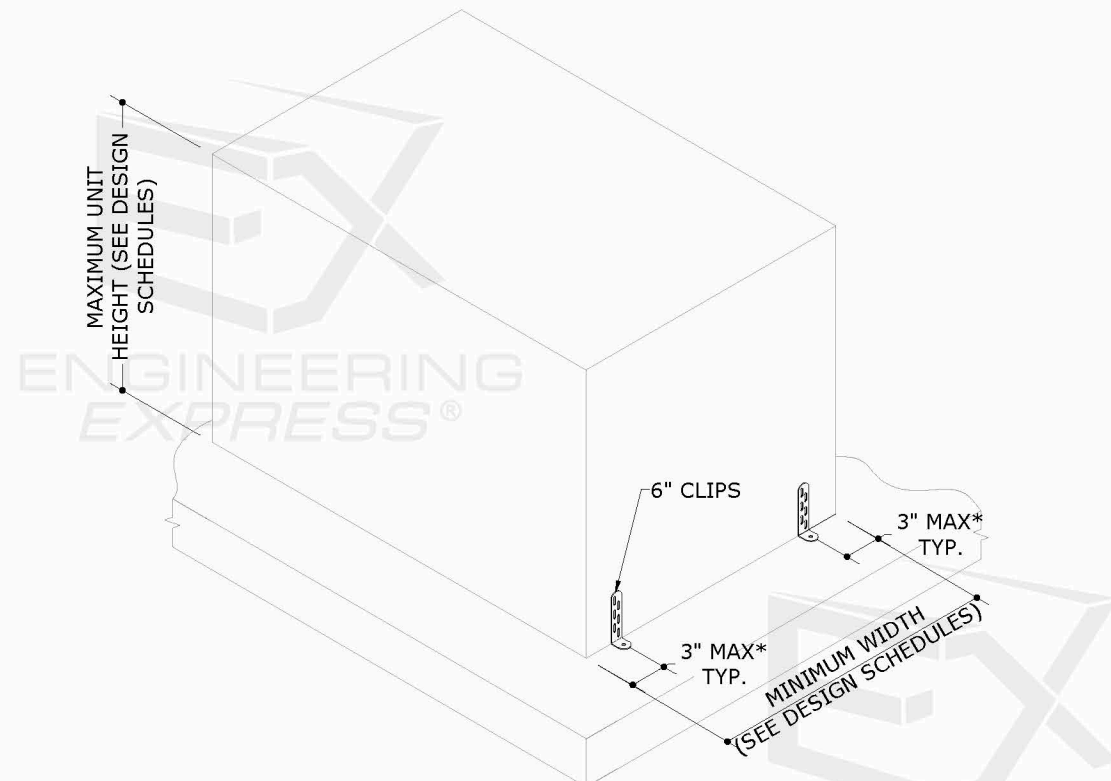

**C1 CONNECTION TYPE C1**  
 1"X6" CLIP - UTILIZE (1) AT EACH CORNER FOR A TOTAL OF (4) PER UNIT  
 NOTE: ALSO APPLICABLE FOR CLIP 4" LONG

\*NOTE: SEE ANCHOR TO HOST SCHEDULE FOR ALL EDGE DISTANCE TO ANCHOR SPACING LIMITATIONS. SEE PAGE 4.

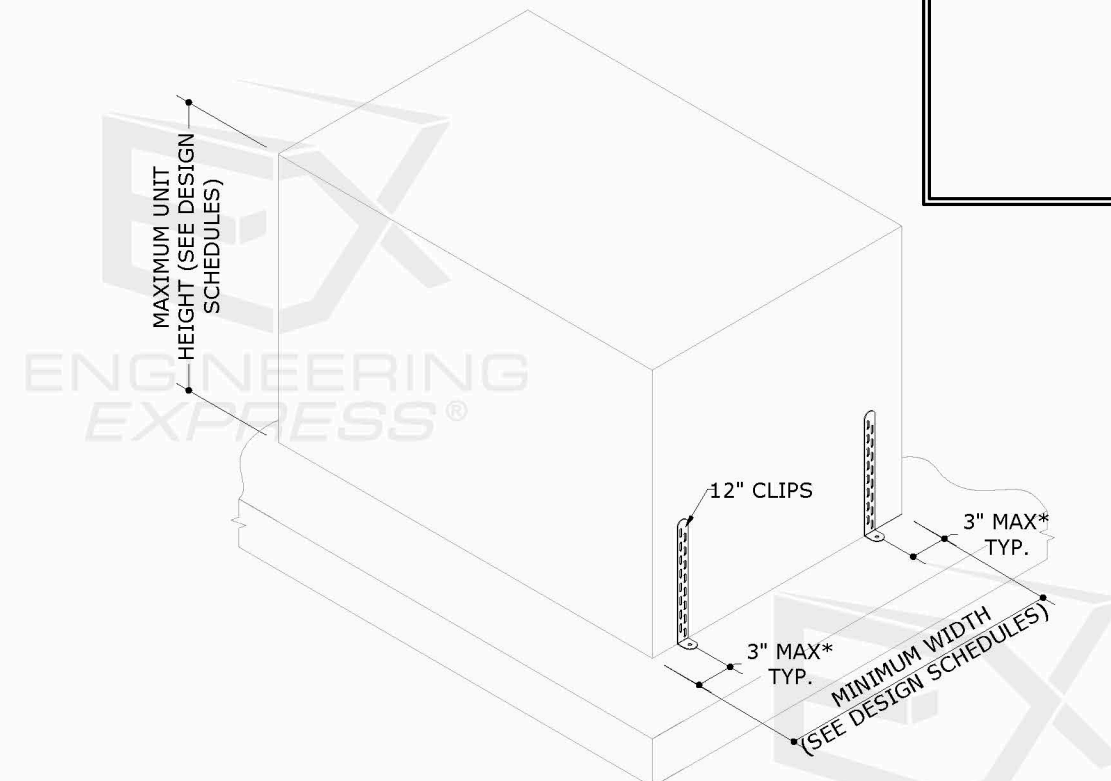

**C3 CONNECTION TYPE C3**  
 1"X12" CLIP - UTILIZE (1) AT EACH CORNER FOR A TOTAL OF (4) PER UNIT  
 NOTE: ALSO APPLICABLE FOR CLIPS 8" & 10" LONG

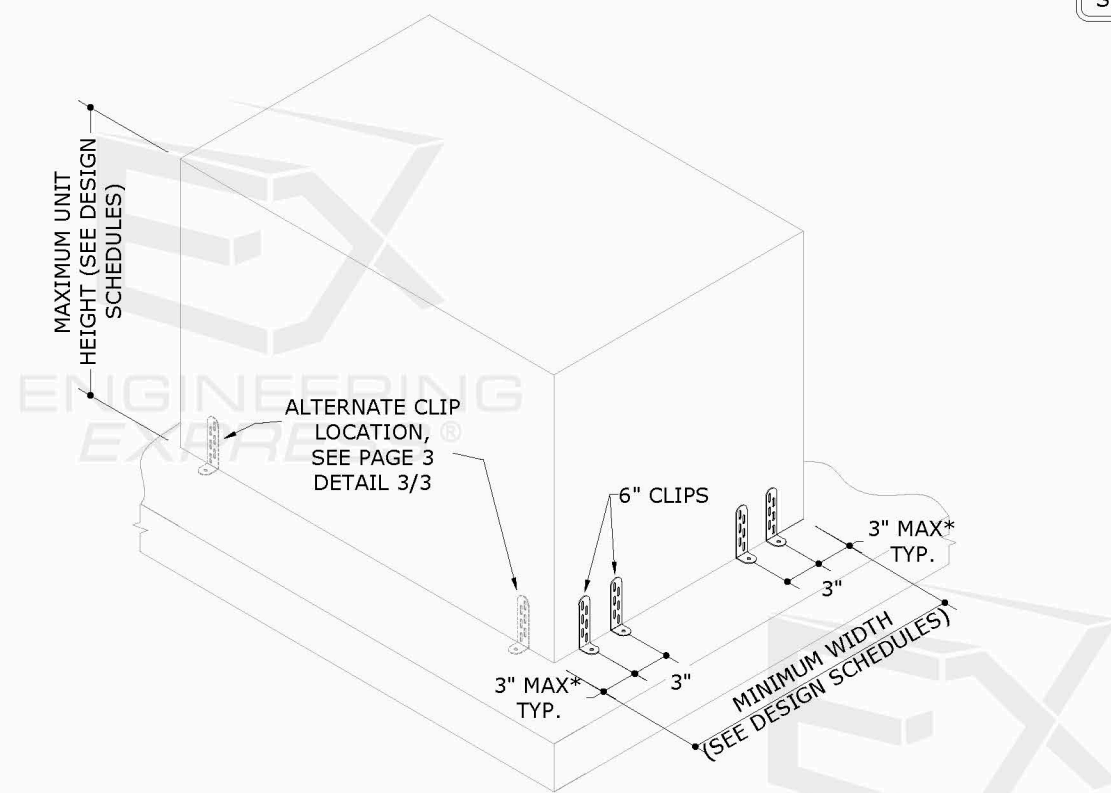

**C2 CONNECTION TYPE C2**  
 1"X6" CLIP - UTILIZE (2) AT EACH CORNER FOR A TOTAL OF (8) PER UNIT  
 NOTE: ALSO APPLICABLE FOR CLIP 4" LONG

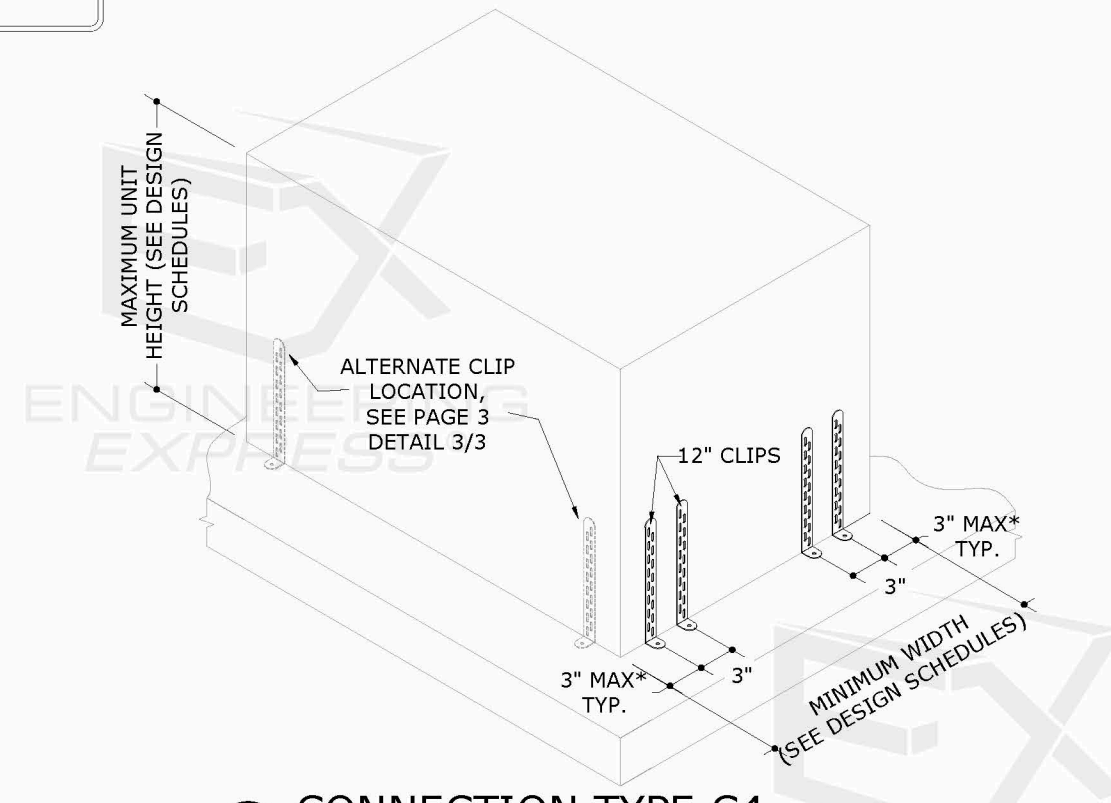

**C4 CONNECTION TYPE C4**  
 1"X12" CLIP - UTILIZE (2) AT EACH CORNER FOR A TOTAL OF (8) PER UNIT  
 NOTE: ALSO APPLICABLE FOR CLIPS 8" & 10" LONG

c:\users\rickn\engineering\express\production - documents\projects\23-123-61594 multiple products 2023 fbc update fl19731.2\2023 fbc update fl19731.2\23-61594b-fl19731.2-doc.dwg

ENGINEERING EXPRESS®

ENGINEERING EXPRESS®

ENGINEERING EXPRESS®

ENGINEERING EXPRESS®

ENGINEERING EXPRESS®

ENGINEERING EXPRESS®



### ATTACHMENT TO STAND

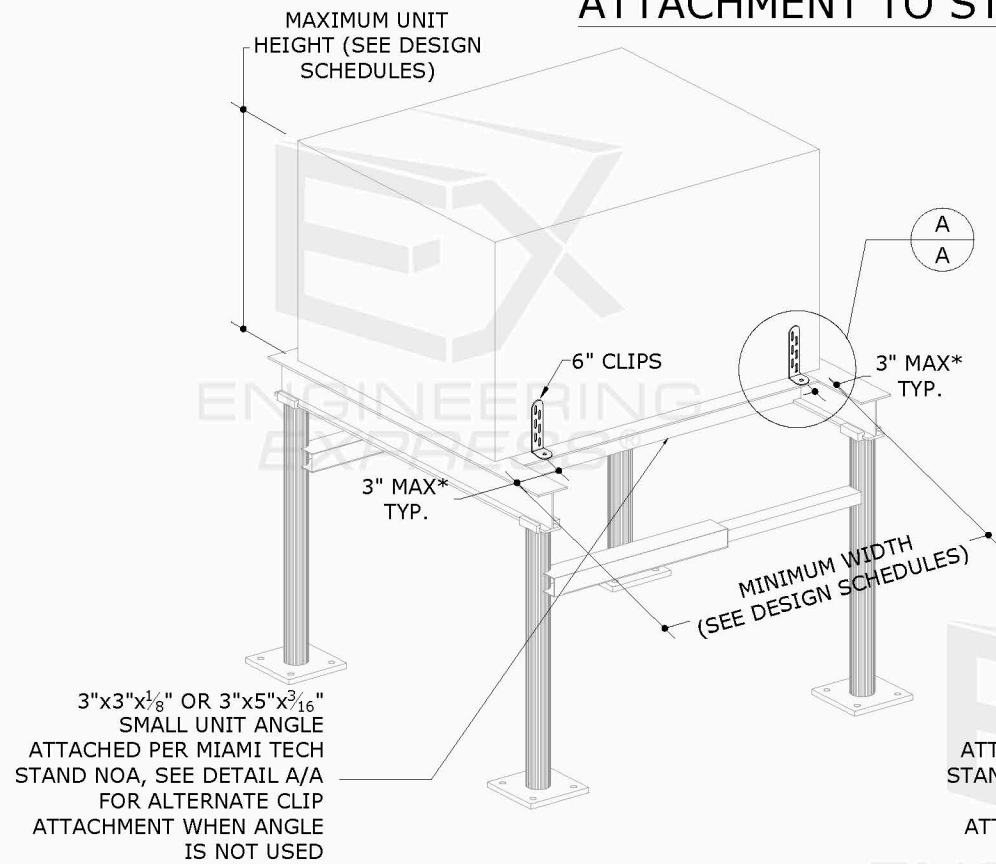

**C1 CONNECTION TYPE C1**  
1"x6" CLIP - UTILIZE (1) AT EACH CORNER FOR A TOTAL OF (4) PER UNIT  
NOTE: ALSO APPLICABLE FOR CLIP 4" LONG

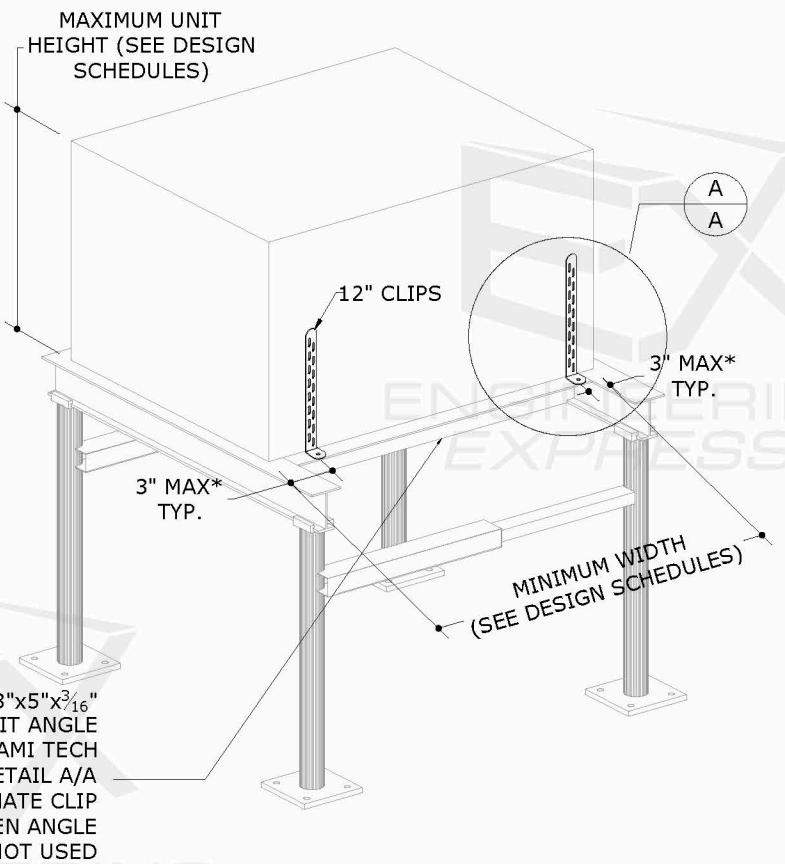

**C3 CONNECTION TYPE C3**  
1"x12" CLIP - UTILIZE (1) AT EACH CORNER FOR A TOTAL OF (4) PER UNIT  
NOTE: ALSO APPLICABLE FOR CLIPS 8" & 10" LONG

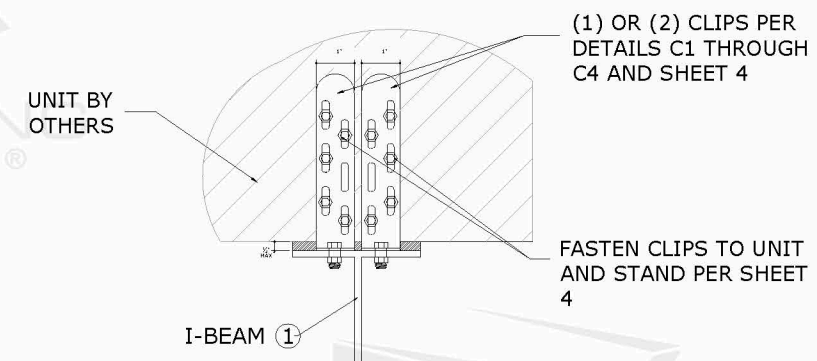

**A ALTERNATE CLIP TO STAND DETAIL**  
SCALE: N.T.S.

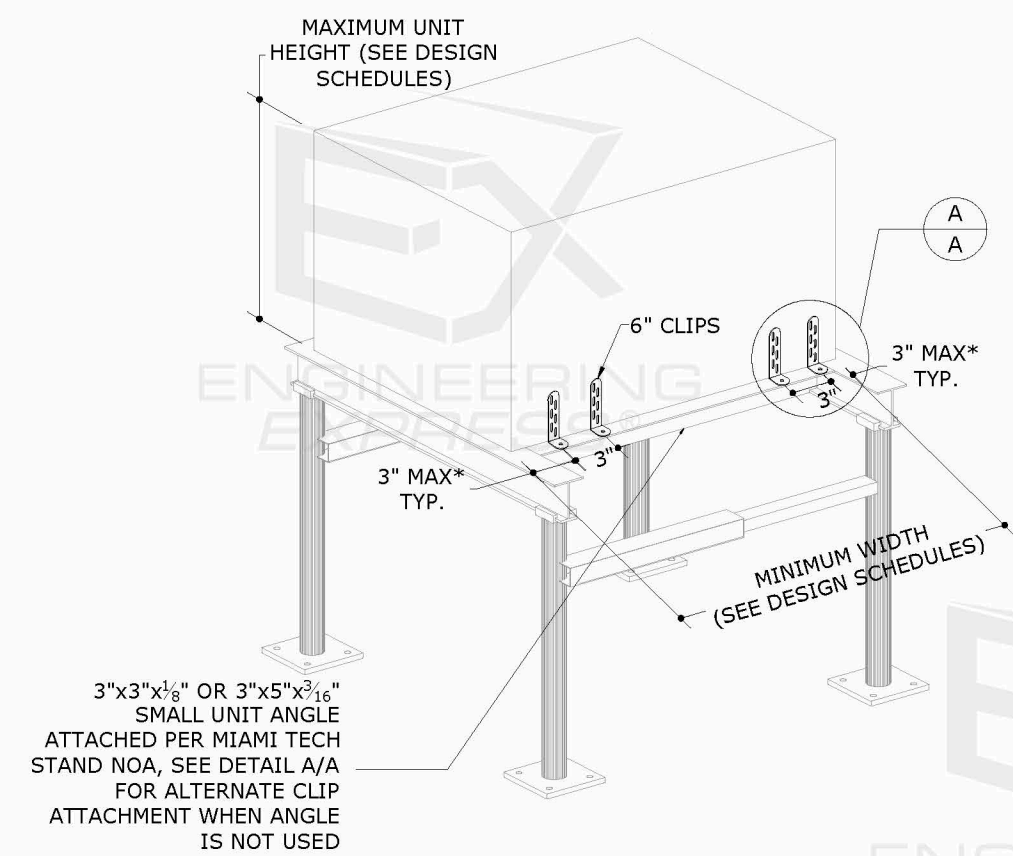

**C2 CONNECTION TYPE C2**  
1"x6" CLIP - UTILIZE (2) AT EACH CORNER FOR A TOTAL OF (8) PER UNIT  
NOTE: ALSO APPLICABLE FOR CLIP 4" LONG

\*NOTE: SEE ANCHOR TO HOST SCHEDULE FOR ALL EDGE DISTANCE TO ANCHOR SPACING LIMITATIONS. SEE PAGE 4.

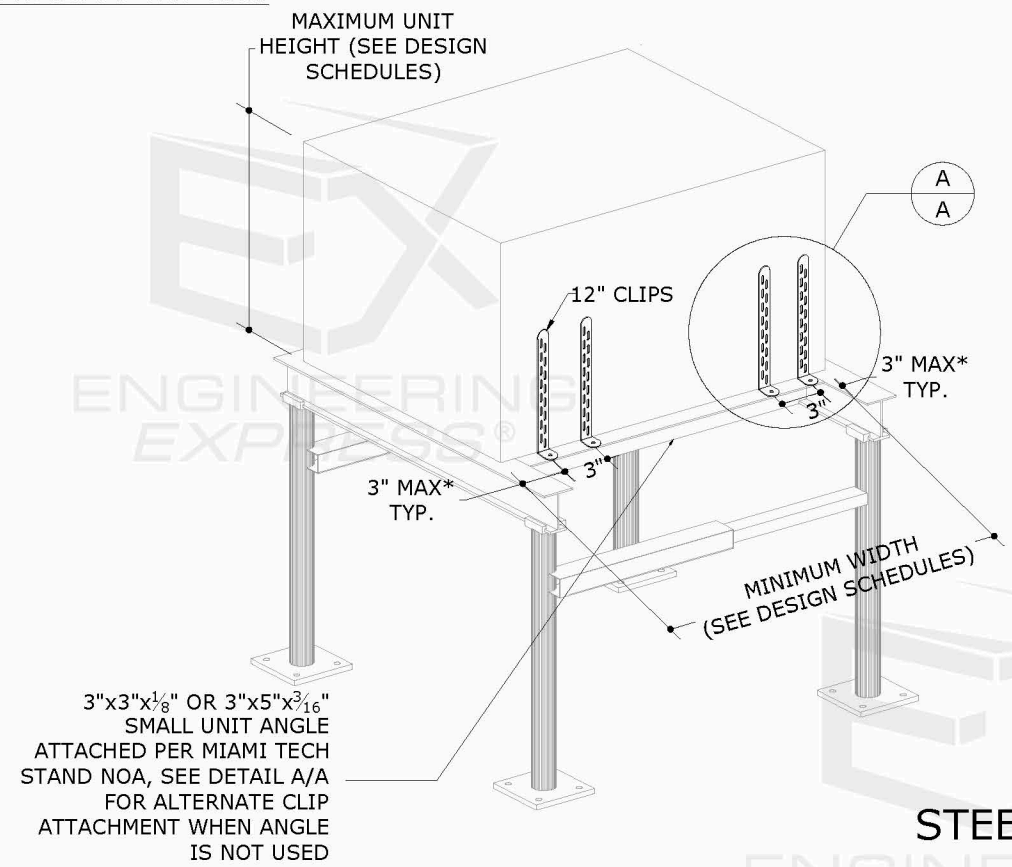

**C4 CONNECTION TYPE C4**  
1"x12" CLIP - UTILIZE (2) AT EACH CORNER FOR A TOTAL OF (8) PER UNIT  
NOTE: ALSO APPLICABLE FOR CLIPS 8" & 10" LONG

### STEEL TIE-DOWN CLIP

FL19731.2

**ENGINEERING EXPRESS**  
POSTAL ADDRESS:  
401 W. ATLANTIC AVE R10 BOX 219  
DELRAY BEACH, FL 33444  
ENGINEERINGEXPRESS.COM

**MIAMI TECH, INC**  
361 NW, 74TH ST  
MIAMI, FL 33147  
(305) 693 - 7054  
MIAMI TECH TIE DOWN CLIP  
FL STATEWIDE APPROVAL  
FLORIDA BUILDING CODE

REMARKS	DRWN	CHKD	DATE
INIT ISSUE	LAO	TSB	2/05/16
2017 FCC	LAO	FLB	8/14/17
2020 FCC	CCB	RWN	6/09/20
2021 FORMATTING	CCH	RWN	11/19/21
2023 FCC	RN	RN	8-15-23

23-61594

SCALE: NTS UNLESS NOTED

c:\users\vrickn\engineering\express\production - documents\projects\23-123-61594\multiple products 2023 fbc update fl19731.2\2023 fbc update fl19731.2\2023 fbc update fl19731.2-dwg



FL19731.2

**ENGINEERING EXPRESS®**  
 POSTAL ADDRESS:  
 401 W. ATLANTIC AVE R10 BOX 219  
 DELRAY BEACH, FL 33444  
 ENGINEERINGEXPRESS.COM

**MIAMI TECH, INC**  
 361 NW, 74TH ST  
 MIAMI, FL 33147  
 (305) 693 - 7054  
 MIAMI TECH TIE DOWN CLIP  
 FL STATEWIDE APPROVAL  
 FLORIDA BUILDING CODE

REMARKS	DRWN	CHKD	DATE
INIT ISSUE	LAO	TSB	2/05/16
2017 FBC	LAO	FLB	8/14/17
2020 FBC	CCB	RWN	6/09/20
2021 FORMATTING	CCH	RWN	11/19/21
2023 FBC	RN	RN	8-15-23

23-61594

SCALE: NTS UNLESS NOTED

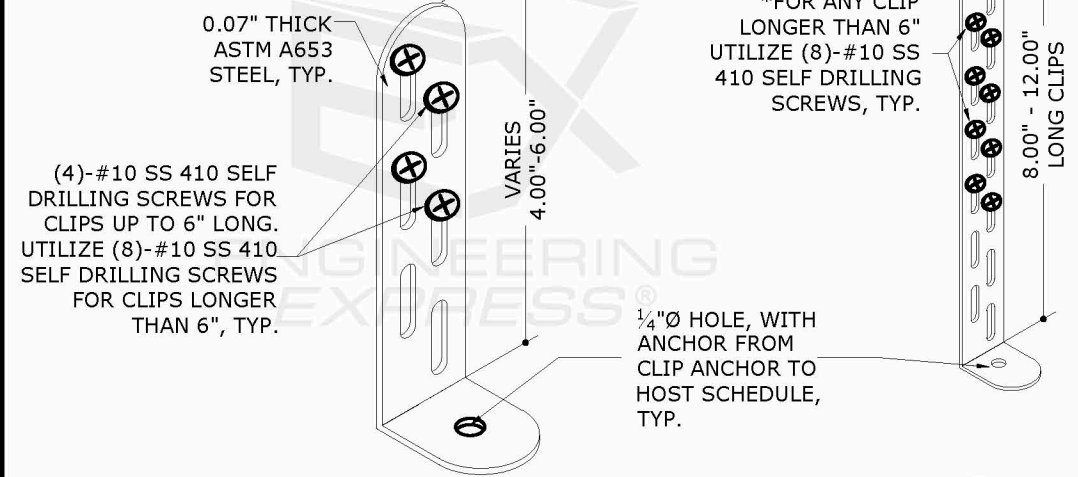

**1 1" CLIP ISOMETRIC DETAIL**  
 4 N.T.S. ISOMETRIC

MECHANICAL UNIT BY OTHERS. ALUMINUM HOUSING UNITS SHALL BE 6063-T6 MIN. ALUMINUM SHEET WITH  $F_{ty}=30$  KSI, 0.125" MIN. THICKNESS, STEEL HOUSING UNITS SHALL BE ASTM A653  $F_y=33$ KSI MIN. STEEL, GRADE 33, 22GA MIN. ( $t=0.0299$ ).

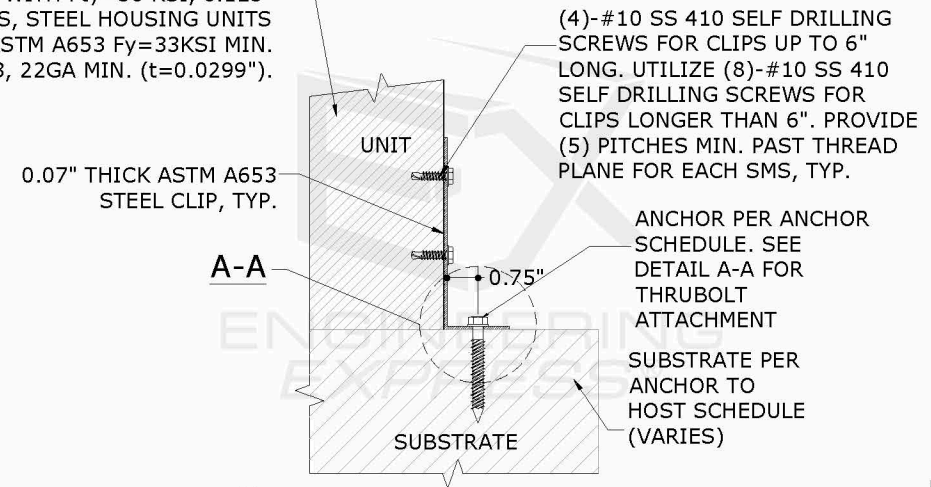

**2 1" TIE-DOWN CLIP ANCHOR DETAIL**  
 4 3" = 1'-0" DETAIL

CLIP IS DESIGNED FOR FULL CONTACT WITH THE BASE OF EACH MECHANICAL UNIT, TYP.

**ANCHOR TO HOST SCHEDULE:**

SUBSTRATE	DESCRIPTION
CONCRETE: (4" THICK MIN, 3000 PSI MIN.)	(1)-1/4"Ø STAINLESS STEEL 410 DEWALT ULTRACON, 1 3/4" FULL EMBED TO CONCRETE, 2 1/2" MIN. EDGE DISTANCE, 3" MIN. SPACING TO ANY ADJACENT ANCHOR.
ALUMINUM: (0.125" MIN. THICK, 6061-T6 MIN. ALUMINUM)	(1)-#14 SAE STAINLESS STEEL BOLT 410 WITH NUT AND WASHER TOP & BOTTOM SS OD 1", 1/2" MINIMUM EDGE DISTANCE TO METAL EDGE
STEEL: (0.125" MIN. THICK, 50 KSI MIN. STEEL)	(1)-#14 SAE STAINLESS STEEL BOLT 410 WITH NUT AND WASHER TOP & BOTTOM SS OD 1", 1/2" MINIMUM EDGE DISTANCE TO METAL EDGE

1. EMBEDMENT AND EDGE DISTANCE EXCLUDES FINISHES, IF APPLICABLE.
2. ENSURE MINIMUM EDGE DISTANCE AS NOTED IN ANCHOR SCHEDULE.
3. ENSURE MINIMUM SPACING TO ANY ADJACENT ANCHORS.
4. SEE DETAILS ON SHEET 4 FOR ANCHORS ATTACHING TO MECHANICAL UNIT.
5. PROTECT ALL METALS FROM DISSIMILAR METALS GENERAL NOTE #5

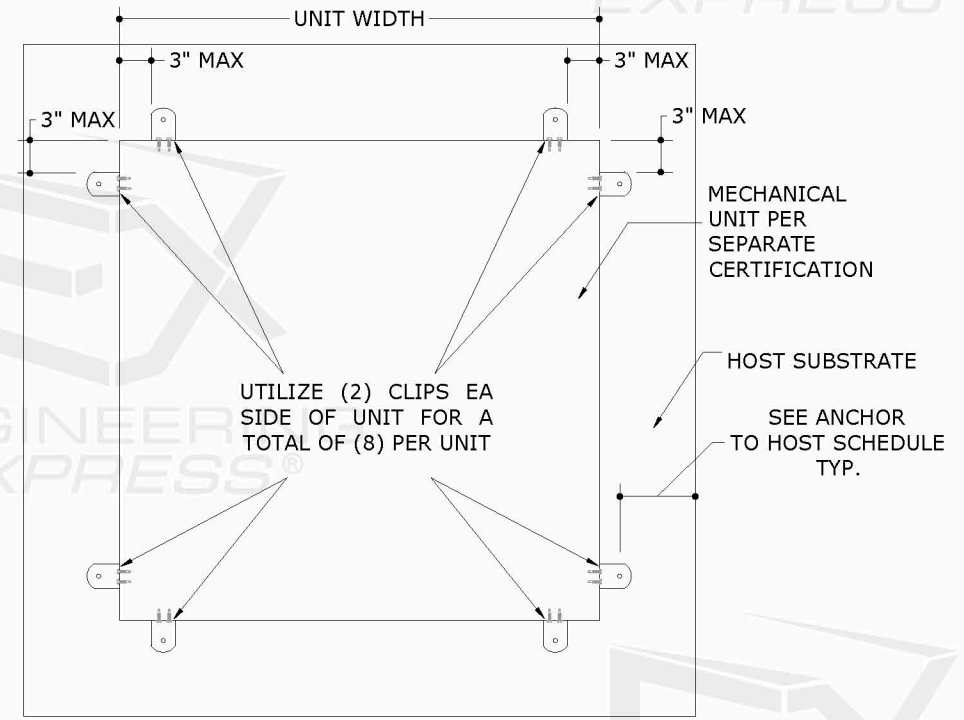

**3 ALTERNATE (8) CLIP DETAIL**  
 4 N.T.S. PLAN VIEW

THIS DETAIL MAY BE USED AS AN ALTERNATE GEOMETRIC PATTERN FOR ALL CONNECTION TYPES THAT UTILIZE (2) CLIPS AT EACH CORNER FOR A TOTAL OF (8) CLIPS PER UNIT.

**STEEL TIE-DOWN CLIP**

c:\users\rickn\engineering\express\production - documents\projects\23-123-61594 - multiple products 2023 fbc update fl19731.2\2023 fbc\work\drawings & cad\23-61594b-fl19731.2-doc.dwg

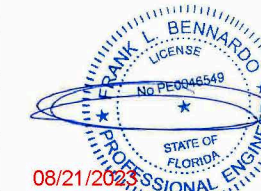

**TABLE 1 PERMISSIBLE INSTALLATION HEIGHTS:  $v_{ult}=175$  MPH, EXPOSURE C**

(FOR USE WITH A RISK CATEGORY II STRUCTURE IN THE HIGH VELOCITY HURRICANE ZONE (HVHZ)\*)  
RISK CATEGORY II IS PER ASCE 7-16

MAXIMUM SURFACE AREA OF UNIT'S LARGEST FACE	UNIT HEIGHT	UNIT WIDTH	ALLOWABLE ROOF-TOP HEIGHT (H) TIE-DOWN CONFIGURATION TYPE			
			C1	C2	C3	C4
6 FT <sup>2</sup>	29" MAX	15" MIN	AT GRADE	H ≤ 200 FT	AT GRADE	H ≤ 200 FT
9 FT <sup>2</sup>	36" MAX	27" MIN	AT GRADE	H ≤ 200 FT	AT GRADE	H ≤ 200 FT
4 FT <sup>2</sup>	48" MAX	36" MIN	H ≤ 160 FT	H ≤ 200 FT	H ≤ 200 FT	H ≤ 200 FT
6 FT <sup>2</sup>			H ≤ 15 FT	H ≤ 200 FT	H ≤ 30 FT	H ≤ 200 FT
9 FT <sup>2</sup>			AT GRADE	H ≤ 200 FT	AT GRADE	H ≤ 200 FT
12 FT <sup>2</sup>			N/A	H ≤ 60 FT	N/A	H ≤ 100 FT
16 FT <sup>2</sup>	60" MAX	48" MIN	N/A	H ≤ 15 FT	N/A	H ≤ 15 FT
20 FT <sup>2</sup>			N/A	AT GRADE	N/A	AT GRADE
25 FT <sup>2</sup>			N/A	AT GRADE	N/A	AT GRADE
30 FT <sup>2</sup>			N/A	N/A	N/A	N/A
36 FT <sup>2</sup>			N/A	N/A	N/A	N/A

\*THIS TABLE IS PERMISSIBLE TO BE USED WITHIN THE HVHZ WHICH CONTAINS BROWARD AND MIAMI-DADE COUNTIES. CHECK WITH LOCAL AUTHORITY HAVING JURISDICTION FOR THE APPLICABILITY OF THIS TABLE WITHIN CERTAIN FLORIDA COUNTIES.

**TABLE 2 PERMISSIBLE INSTALLATION HEIGHTS:  $v_{ult}=175$  MPH, EXPOSURE D**

(FOR USE WITH A RISK CATEGORY II STRUCTURE IN THE HIGH VELOCITY HURRICANE ZONE (HVHZ)\*)  
RISK CATEGORY II IS PER ASCE 7-16

MAXIMUM SURFACE AREA OF UNIT'S LARGEST FACE	UNIT HEIGHT	UNIT WIDTH	ALLOWABLE ROOF-TOP HEIGHT (H) TIE-DOWN CONFIGURATION TYPE			
			C1	C2	C3	C4
6 FT <sup>2</sup>	29" MAX	15" MIN	N/A	H ≤ 200 FT	AT GRADE	H ≤ 200 FT
9 FT <sup>2</sup>	36" MAX	27" MIN	N/A	H ≤ 140 FT	N/A	H ≤ 200 FT
4 FT <sup>2</sup>	48" MAX	36" MIN	H ≤ 80 FT	H ≤ 200 FT	H ≤ 140 FT	H ≤ 200 FT
6 FT <sup>2</sup>			AT GRADE	H ≤ 200 FT	AT GRADE	H ≤ 200 FT
9 FT <sup>2</sup>			N/A	H ≤ 160 FT	AT GRADE	H ≤ 200 FT
12 FT <sup>2</sup>			N/A	H ≤ 30 FT	N/A	H ≤ 40 FT
16 FT <sup>2</sup>	60" MAX	48" MIN	N/A	AT GRADE	N/A	AT GRADE
20 FT <sup>2</sup>			N/A	AT GRADE	N/A	AT GRADE
25 FT <sup>2</sup>			N/A	N/A	N/A	N/A
30 FT <sup>2</sup>			N/A	N/A	N/A	N/A
36 FT <sup>2</sup>			N/A	N/A	N/A	N/A

\*THIS TABLE IS PERMISSIBLE TO BE USED WITHIN THE HVHZ WHICH CONTAINS BROWARD AND MIAMI-DADE COUNTIES. CHECK WITH LOCAL AUTHORITY HAVING JURISDICTION FOR THE APPLICABILITY OF THIS TABLE WITHIN CERTAIN FLORIDA COUNTIES.

**TABLE 3 PERMISSIBLE INSTALLATION HEIGHTS:  $v_{ult}=170$  MPH, EXPOSURE C**

(FOR USE WITH A RISK CATEGORY II STRUCTURE\*\*)  
RISK CATEGORY II IS PER ASCE 7-16

MAXIMUM SURFACE AREA OF UNIT'S LARGEST FACE	UNIT HEIGHT	UNIT WIDTH	ALLOWABLE INSTALLATION ROOF HEIGHT TIE-DOWN CONFIGURATION TYPE			
			C1	C2	C3	C4
6 ft <sup>2</sup>	29 in	15 in	AT GRADE	≤ 200 FT	AT GRADE	≤ 200 FT
9 ft <sup>2</sup>	36 in	27 in	AT GRADE	≤ 200 FT	AT GRADE	≤ 200 FT
4 ft <sup>2</sup>	48 in	36 in	≤ 200 FT	≤ 200 FT	≤ 200 FT	≤ 200 FT
6 ft <sup>2</sup>	48 in	36 in	H ≤ 30 FT	≤ 200 FT	H ≤ 40 FT	≤ 200 FT
9 ft <sup>2</sup>	48 in	36 in	AT GRADE	≤ 200 FT	AT GRADE	≤ 200 FT
12 ft <sup>2</sup>	48 in	36 in	N/A	≤ 80 FT	N/A	≤ 140 FT
16 ft <sup>2</sup>	48 in	36 in	N/A	H ≤ 15 FT	N/A	H ≤ 30 FT
20 ft <sup>2</sup>	60 in	48 in	N/A	AT GRADE	N/A	AT GRADE
25 ft <sup>2</sup>	60 in	48 in	N/A	AT GRADE	N/A	AT GRADE
30 ft <sup>2</sup>	60 in	48 in	N/A	N/A	N/A	AT GRADE
36 ft <sup>2</sup>	60 in	48 in	N/A	N/A	N/A	N/A

\*\*AS AN EXAMPLE, THESE TABLES ARE PERMISSIBLE TO BE USED WITHIN PALM BEACH COUNTY. CHECK WITH LOCAL AUTHORITY HAVING JURISDICTION FOR THE APPLICABILITY OF THESE TABLES WITHIN CERTAIN FLORIDA COUNTIES.

**TABLE 4 PERMISSIBLE INSTALLATION HEIGHTS:  $v_{ult}=170$  MPH, EXPOSURE D**

(FOR USE WITH A RISK CATEGORY II STRUCTURE\*\*)  
RISK CATEGORY II IS PER ASCE 7-16

MAXIMUM SURFACE AREA OF UNIT'S LARGEST FACE	UNIT HEIGHT	UNIT WIDTH	ALLOWABLE INSTALLATION ROOF HEIGHT TIE-DOWN CONFIGURATION TYPE			
			C1	C2	C3	C4
6 ft <sup>2</sup>	29 in	15 in	AT GRADE	≤ 200 FT	AT GRADE	≤ 200 FT
9 ft <sup>2</sup>	36 in	27 in	N/A	≤ 200 FT	AT GRADE	≤ 200 FT
4 ft <sup>2</sup>	48 in	36 in	≤ 120 FT	≤ 200 FT	≤ 200 FT	≤ 200 FT
6 ft <sup>2</sup>	48 in	36 in	AT GRADE	≤ 200 FT	H ≤ 15 FT	≤ 200 FT
9 ft <sup>2</sup>	48 in	36 in	N/A	≤ 200 FT	AT GRADE	≤ 200 FT
12 ft <sup>2</sup>	48 in	36 in	N/A	H ≤ 40 FT	N/A	H ≤ 60 FT
16 ft <sup>2</sup>	48 in	36 in	N/A	AT GRADE	N/A	AT GRADE
20 ft <sup>2</sup>	60 in	48 in	N/A	AT GRADE	N/A	AT GRADE
25 ft <sup>2</sup>	60 in	48 in	N/A	N/A	N/A	N/A
30 ft <sup>2</sup>	60 in	48 in	N/A	N/A	N/A	N/A
36 ft <sup>2</sup>	60 in	48 in	N/A	N/A	N/A	N/A

FL19731.2

**ENGINEERING EXPRESS®**  
POSTAL ADDRESS:  
401 W. ATLANTIC AVE R10 BOX 219  
DELRAY BEACH, FL 33444  
ENGINEERINGEXPRESS.COM

**MIAMI TECH, INC**  
361 NW, 74TH ST  
MIAMI, FL 33147  
(305) 693 - 7054  
MIAMI TECH TIE DOWN CLIP  
FL STATEWIDE APPROVAL  
FLORIDA BUILDING CODE

DATE	DRWN	CHKD	REMARKS
2/05/16	LAO	TSB	INIT ISSUE
8/14/17	LAO	FLB	2017 FBC
6/09/20	CCB	RWN	2020 FBC
11/19/21	CCH	RWN	2021 FBC
8-15-23	RN	RN	2023 FBC

23-61594

SCALE: NTS UNLESS NOTED



STEEL TIE-DOWN CLIP

8/18/2023 5:26 PM RICKN c:\users\rickn\engineering\express\production - documents\projects\23-123-61594 multiple products 2023 fbc update fl19731.2\2023 fbc\work\drawings & cad\23-61594b-fl19731.2-doc.dwg

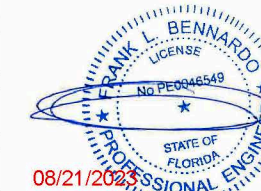

**TABLE 5 PERMISSIBLE INSTALLATION HEIGHTS:  $V_{ult}=140$  MPH, EXPOSURE B**

(FOR USE WITH A RISK CATEGORY II STRUCTURE\*\*\*)  
RISK CATEGORY II IS PER ASCE 7-16

MAXIMUM SURFACE AREA OF UNIT'S LARGEST FACE	UNIT HEIGHT	UNIT WIDTH	ALLOWABLE INSTALLATION ROOF HEIGHT TIE-DOWN CONFIGURATION TYPE			
			C1	C2	C3	C4
6 ft <sup>2</sup>	29 in	15 in	≤ 100 FT	≤ 200 FT	≤ 140 FT	≤ 200 FT
9 ft <sup>2</sup>	36 in	27 in	≤ 80 FT	≤ 200 FT	≤ 100 FT	≤ 200 FT
4 ft <sup>2</sup>	48 in	36 in	≤ 200 FT	≤ 200 FT	≤ 200 FT	≤ 200 FT
6 ft <sup>2</sup>	48 in	36 in	≤ 200 FT	≤ 200 FT	≤ 200 FT	≤ 200 FT
9 ft <sup>2</sup>	48 in	36 in	≤ 80 FT	≤ 200 FT	≤ 120 FT	≤ 200 FT
12 ft <sup>2</sup>	48 in	36 in	H ≤ 30 FT	≤ 200 FT	H ≤ 40 FT	≤ 200 FT
16 ft <sup>2</sup>	48 in	36 in	AT GRADE	≤ 200 FT	H ≤ 15 FT	≤ 200 FT
20 ft <sup>2</sup>	60 in	48 in	AT GRADE	≤ 160 FT	AT GRADE	≤ 200 FT
25 ft <sup>2</sup>	60 in	48 in	N/A	H ≤ 60 FT	AT GRADE	≤ 100 FT
30 ft <sup>2</sup>	60 in	48 in	N/A	H ≤ 30 FT	N/A	H ≤ 40 FT
36 ft <sup>2</sup>	60 in	48 in	N/A	H ≤ 15 FT	N/A	H ≤ 15 FT

**TABLE 6 PERMISSIBLE INSTALLATION HEIGHTS:  $V_{ult}=140$  MPH, EXPOSURE C**

(FOR USE WITH A RISK CATEGORY II STRUCTURE\*\*\*)  
RISK CATEGORY II IS PER ASCE 7-16

MAXIMUM SURFACE AREA OF UNIT'S LARGEST FACE	UNIT HEIGHT	UNIT WIDTH	ALLOWABLE INSTALLATION ROOF HEIGHT TIE-DOWN CONFIGURATION TYPE			
			C1	C2	C3	C4
6 ft <sup>2</sup>	29 in	15 in	H ≤ 30 FT	≤ 200 FT	H ≤ 40 FT	≤ 200 FT
9 ft <sup>2</sup>	36 in	27 in	H ≤ 15 FT	≤ 200 FT	H ≤ 30 FT	≤ 200 FT
4 ft <sup>2</sup>	48 in	36 in	≤ 200 FT	≤ 200 FT	≤ 200 FT	≤ 200 FT
6 ft <sup>2</sup>	48 in	36 in	≤ 200 FT	≤ 200 FT	≤ 200 FT	≤ 200 FT
9 ft <sup>2</sup>	48 in	36 in	H ≤ 15 FT	≤ 200 FT	H ≤ 40 FT	≤ 200 FT
12 ft <sup>2</sup>	48 in	36 in	AT GRADE	≤ 200 FT	AT GRADE	≤ 200 FT
16 ft <sup>2</sup>	48 in	36 in	N/A	≤ 140 FT	AT GRADE	≤ 200 FT
20 ft <sup>2</sup>	60 in	48 in	N/A	H ≤ 40 FT	N/A	≤ 80 FT
25 ft <sup>2</sup>	60 in	48 in	N/A	H ≤ 15 FT	N/A	H ≤ 30 FT
30 ft <sup>2</sup>	60 in	48 in	N/A	AT GRADE	N/A	AT GRADE
36 ft <sup>2</sup>	60 in	48 in	N/A	AT GRADE	N/A	AT GRADE

**TABLE 7 PERMISSIBLE INSTALLATION HEIGHTS:  $V_{ult}=140$  MPH, EXPOSURE D**

(FOR USE WITH A RISK CATEGORY II STRUCTURE\*\*\*)  
RISK CATEGORY II IS PER ASCE 7-16

MAXIMUM SURFACE AREA OF UNIT'S LARGEST FACE	UNIT HEIGHT	UNIT WIDTH	ALLOWABLE INSTALLATION ROOF HEIGHT TIE-DOWN CONFIGURATION TYPE			
			C1	C2	C3	C4
6 ft <sup>2</sup>	29 in	15 in	AT GRADE	≤ 200 FT	H ≤ 15 FT	≤ 200 FT
9 ft <sup>2</sup>	36 in	27 in	AT GRADE	≤ 200 FT	AT GRADE	≤ 200 FT
4 ft <sup>2</sup>	48 in	36 in	≤ 200 FT	≤ 200 FT	≤ 200 FT	≤ 200 FT
6 ft <sup>2</sup>	48 in	36 in	≤ 100 FT	≤ 200 FT	≤ 180 FT	≤ 200 FT
9 ft <sup>2</sup>	48 in	36 in	AT GRADE	≤ 200 FT	H ≤ 15 FT	≤ 200 FT
12 ft <sup>2</sup>	48 in	36 in	AT GRADE	≤ 200 FT	AT GRADE	≤ 200 FT
16 ft <sup>2</sup>	48 in	36 in	N/A	≤ 80 FT	N/A	≤ 120 FT
20 ft <sup>2</sup>	60 in	48 in	N/A	H ≤ 15 FT	N/A	H ≤ 40 FT
25 ft <sup>2</sup>	60 in	48 in	N/A	AT GRADE	N/A	AT GRADE
30 ft <sup>2</sup>	60 in	48 in	N/A	AT GRADE	N/A	AT GRADE
36 ft <sup>2</sup>	60 in	48 in	N/A	N/A	N/A	AT GRADE

\*\*\*AS AN EXAMPLE, THESE TABLES ARE PERMISSIBLE TO BE USED WITHIN BREVARD COUNTY. CHECK WITH LOCAL AUTHORITY HAVING JURISDICTION FOR THE APPLICABILITY OF THIS TABLE WITHIN CERTAIN FLORIDA COUNTIES.

FL19731.2

**ENGINEERING EXPRESS®**  
POSTAL ADDRESS:  
401 W. ATLANTIC AVE R10 BOX 219  
DELRAY BEACH, FL 33444  
ENGINEERINGEXPRESS.COM

**MIAMI TECH, INC**

361 NW, 74TH ST  
MIAMI, FL 33147  
(305) 693 - 7054

MIAMI TECH TIE DOWN CLIP  
FL STATEWIDE APPROVAL  
FLORIDA BUILDING CODE

REMARKS	DRWN	CHKD	DATE
INIT ISSUE	LAO	TSB	2/05/16
2017 FCC	LAO	FLB	8/14/17
2020 FCC	CCB	RWN	6/09/20
2021 FORMATTING	CCH	RWN	11/19/21
2023 FCC	RN	RN	8-15-23

COPYRIGHT ENGINEERING EXPRESS®

23-61594

SCALE: NTS UNLESS NOTED



STEEL TIE-DOWN CLIP

c:\users\rickn\engineering\express\production - documents\projects\23-123-61594 multiple products 2023 fbc update fl19731.2023 fbc\work\drawings & cad\23-61594b-fl19731.2-doc.dwg